



Award winning solution for tunnelling operation



Solution for Thermax Babcock & Wilcox to reduce project costs



Tower cranes for India's largest cooling towers

EMPOWER

Lifting & Handling



First Single Failure Proof Crane For Nuclear Reactor Dome Delivered To Kakrapar Atomic Power Project

Contents

ElectroMech FZE receives a major order from Air Liquide Group of France	02	A 'plate' full of challenges	13
From MD's desk	03	Zoomlion Tower Cranes for one of India's largest Cooling Towers	14-15
Story of unfailing commitment to deliver first Single Failure Proof EOT Crane to NPCIL	04-07	A new lease of life to a worn out crane for HCC's DMRC project	16-17
CMI FPE trusts our solutions capability	08	Cranedge introduces unmatched, localised services for Zoomlion Tower Cranes	16-17
Prestigious order from Mazgaon Dock Limited	09	Award-winning solution for tunnelling operations	18
How project costs can be saved by involving ElectroMech at plant designing stage A testimony at Thermax Babcock & Wilcox Ltd., Pune ..	10-11	Our customers reaffirm our positioning Solutions, Service, Satisfaction	19
Forging relationship	12	Zoomlion - ElectroMech Tower Cranes make a debut at bC India, 2013	20
Thermax Babcock & Wilcox reposes its trust in ElectroMech	12		



ElectroMech FZE

| Solutions | Service | Satisfaction |

Receives a major order from Air Liquide Group of France



Air Liquide Group is a major player in the oil & gas sector as well as health & environment with operations in over 80 countries. It is

the world leader in gases for industry, health and environment. The Group offers innovative solutions based on continuously enhanced technologies for cold box manufacturing which is used in Air Separation Units / Cryogenic Air Separation Units (ASUs).

In a major breakthrough, our subsidiary, ElectroMech FZE, Dubai bagged a **major order worth approx. INR 200 million for 29 EOT Cranes from the French multinational, Air Liquide Group.** The order was received against tough competition from several multinational companies.

Our complete scope is for the manufacture, supply, erection, commissioning, testing and certification of 29 EOT Cranes.

The cranes to be supplied are:

- > 150MT DGEOT - 2 nos. > 20MT DGEOT - 11 nos.
- > 10MT SGEOT - 14 nos. > 10MT DG Gantry Cranes - 2 nos.

These cranes will be installed in their plant in RAK Maritime City which is the latest and most advanced maritime free zone to open in the United Arab Emirates. The Air Liquide Group plant is spread over 36 acres and the facility will be used for the manufacturing of fabricated metal products, structures, tanks, reservoirs and containers or in short cryogenic vessels.

This challenging project will be completed during FY 2013-14 successfully.



Take my word!

Dear customers, colleagues,
business associates and well-wishers of ElectroMech,

All of us are going through a historically significant phase for the global economy in general and the Indian economy in particular. Many years hence, people will reflect back upon these times and a great deal will be written about the period. In retrospect, everyone would have already had a handle on the situation, but when one is navigating through the turbulent times, one unfortunately does not have the luxury of driving while looking into the rear view mirror. One has to focus on the immediate task at hand and focus on creating a brighter future. On this background, it gives me immense pleasure to familiarise all of you with the achievements of ElectroMech in this period.

The theme of the current issue that has emerged unwittingly is TECHNOLOGY - wherein we have been proudly associated with designing, manufacturing, supplying and commissioning some truly technically advanced solutions for our customers.

ElectroMech FZE, our subsidiary in UAE continues to fly our flag high by securing a very prestigious order for Air Liquide Group's latest plant in Ras Al Khaimah. Please read more about this prestigious order which was won against stiff competition posed by other multinational crane companies.

We are proud to present to you ElectroMech's distinction of being the first in India to indigenously design, manufacture and supply a very unique Single Failure Proof 60t EOT crane to Nuclear Power Corporation's power plant in Kakrapar, Gujarat.

Also read in this issue about several prestigious orders we have received from several customers across India who repose their faith in ElectroMech and our solutions for their diverse handling needs.

ElectroMech has always prided itself in being a solutions provider and a partner that works with its clients to design, develop and execute crane systems that not only address the requirements of the clients, but also does so in an optimum manner. Read about how ElectroMech has helped the joint venture of Thermax Babcock & Wilcox to put up effective and optimum crane systems for their ambitious world-class super critical boiler plant near Pune.

In the last issue, we mentioned about our Joint Venture with Zoomlion for Tower Cranes. In this issue, we are proud to present our successes in this Joint Venture by showcasing a project wherein we supplied 2 nos. of TCT7527-20 Flat Top Tower Cranes for building India's tallest cooling towers in a power plant project being executed by Nagarjuna Construction Company.

Our services subsidiary, Cranedge, true to its philosophy - upkeep, upgrade, upraise - helped one of our prestigious clients, Hindustan Construction Company by breathing a new life in their old cranes which have been redeployed for their construction project of the Delhi Metro Rail.

However, one of the most important achievements of ElectroMech has been reserved for the last as the trump card! ElectroMech has been recognised for its technological competence and its capabilities in deploying unique solutions for the requirement of tunnelling contractors, by 'Manufacturing Today' through an award for 'Excellence in Innovation'. We are extremely proud to be the recipients of such recognition and are looking forward to winning several such awards in the future.

As always, I wish you all a happy reading and want to thank you all for your continued patronage of ElectroMech.



Tushar Mehendale
Managing Director





Nuclear Power Corporation of India Limited (NPCIL) is a Public Sector Enterprise under the administrative control of the Department of Atomic Energy (DAE), Government of India. It was established in 1987 with the objective of operating atomic power stations and implementing atomic power projects for generation of electricity. It is responsible for design, construction, commissioning and operation of nuclear power reactors in India.

For the 3rd and 4th units of its Kakrapar Atomic Power Project near Surat in Gujarat, NPCIL sought a competent and experienced crane manufacturer with the capability to design, manufacture and commission 29 EOT cranes according to the critical requirements of the project while being able to adhere to stringent quality norms. The cranes are to be installed at crucial locations in the reactor building, reactor auxiliary workshop and mechanical workshop of the nuclear plant. The scope of the work also includes the designing of three critical Single Failure Proof Cranes (SFPs).

ElectroMech - Selected as a most reliable project partner

The order was received after a thorough technical and commercial evaluation of the bid, which was followed by a factory visit by a cross-functional team from NPCIL to evaluate our infrastructure and capabilities to execute the order. Satisfied with the capability and competency of ElectroMech, NPCIL placed the package order on ElectroMech in the month of August 2011. The total scope of the work includes design, manufacture, inspection, assembly, shop testing, packing & forwarding, safe delivery to site, unloading, storing, handling at site, erection, final testing commissioning and handing over of cranes as per NPCIL specifications.

This order includes:

- Single Failure Proof Cranes - 3 nos.
- Double Girder EOT Cranes - 6 nos.
- Single Girder Underslung Cranes - 6 nos.

- Gantry Cranes - 4 nos.
- Manually Operated Cranes - 6 nos.
- Chain Hoists - 4 nos.

Among these, one of the most challenging requirements was that of the 60MT Single Failure Proof Crane to be installed in the reactor building.

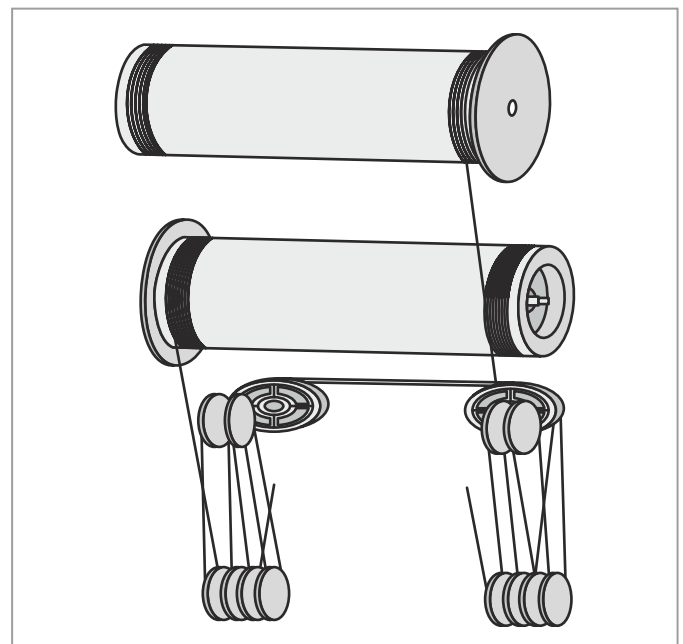

Technical specifications of the 60MT Single Failure Proof Crane

- Crane SWL: 60MT ➤ Span: 21m ➤ HOL: 38m
- Class of duty: M7 ➤ Operation: Cabin, Radio Remote Control & Pendant ➤ Crane weight: 80MT ➤ Crab weight: 30MT
- Hook: 60MT Ramshorn Type Single Failure Proof Hook

In a major international bid, ElectroMech won an order to supply 29 EOT cranes to Nuclear Power Corporation of India (NPCIL) for their Kakrapar Atomic Power Project (KAPP) near Surat in Gujarat. This order includes 3 Single Failure Proof (SFP) Cranes.

Story of unflinching commitment to deliver first Single Failure Proof EOT Crane to NPCIL

What is a Single Failure Proof Crane?

A Single Failure Proof Crane has redundant systems & mechanisms built into it, so that should one system or mechanism fail, the backup system ensures that the work cycle is completed. In the case of these cranes, it means that if a load carrying system or mechanism suffers a failure, the full load is taken by the backup or redundant mechanism. This, in turn, prevents any major catastrophe in case of failure of any load carrying component in the system.

Application

The first crane supplied is mainly to be used for handling Primary Coolant Pump Motors, which are located exactly above the reactor. The secondary application is for erection, maintenance related activities of all the equipments within the reactor building.





Why is this required?

This crane will operate at the top of the Reactor Building dome, directly above the reactor which is the heart of a nuclear power plant. The location of the crane thereby demands a very high level of safety, necessitating the need for a Single Failure Proof Crane.

How is this achieved?

The required redundancy is achieved by using two independent load paths through two rope drums. Both the rope drums are driven by separate gearboxes and motors, synchronised to ensure equal displacement of wire rope in each load path. Each load path is designed to hold the rated load. Both the wire ropes reevings are taken on alternate pulleys to maintain equilibrium of load in case of failure of one rope system. The hooks used are of dual design with dual attaching points thereby if one attachment fails, the other load path continues to support the load without excessive drop or swing.

Project challenges

Design

One of the biggest challenges for the designers was that this Single Failure Proof Crane for the 700MWe reactor was to be made with the same dimensional constraints as a regular EOT crane. Moreover, the span of the crane for the 700MWe reactor is 21m as compared to 10m for a crane in the 500MWe reactors. This made the design and arrangement of the crane components a daunting task while meeting the dimensional requirement. Finally, after months of painstaking efforts, dozens of proposals and several brainstorming sessions, our design team along with the NPCIL design team narrowed down to a double-decked arrangement of the trolley mechanism. The design of this trolley having a height of approximately 6.5m and sitting on top of the reactor building was successfully undertaken by our design team. This new concept was endorsed by the NPCIL team, so much so that the same concept will be adopted in unit 7 of their Rajasthan Atomic Power Plant as well.

Seismic Design

Design to ensure structural integrity during a seismic event was called for. The crane structural needed to be designed for Safe Shutdown Earthquake (SSE) and Operating Base Earthquake (OBE) standards as per the furnished Floor Response Spectra.

For the design and qualification of the plant the Safe Shutdown Earthquake (SSE) standard is adopted. In simple language, this means, in the eventuality of an earthquake it must be possible to

shut down the plant and equipment safely. Similarly, the intensity of the Operating Base Earthquake (OBE) is related to the production period of the Nuclear Power Plant. After an OBE, it should be possible to shut down the plant safely and further operation of the plant and equipment should be possible after checking and a certain amount of repair work.

The Floor Response Spectra is tabulated data that gives the acceleration forces that may act on the crane in the event of an earthquake. These acceleration values are a function of equipment frequency and the elevation (i.e. crane location) amongst many other factors. By using this data given by NPCIL for the particular site location, the structurals of the crane were qualified accordingly.

The ElectroMech design was reviewed by the NPCIL design team and handed over to a third party for analysis using software to simulate more virtual conditions. Finally, after 12 months of detailed engineering and analysis, the structural design was approved.

Procurement, Quality and Production

The special design called for use of special / non-standard materials. For example, MS plates of grade E350 instead of

conventional grade E250 were used for girder fabrication, square tubes were used for trolley fabrication and caliper brakes were used, to mention a few. WPS PQR were re-established to meet the customer requirement as per ASME. Above all, a stringent quality plan was followed whereby material at each stage of its production cycle - from raw material to finished component, was tested to meet the highest quality standards. Obviously, this couldn't be achieved without a very efficient procurement, quality and production team.

Setting new records at ElectroMech

- First Single Failure Proof EOT Crane supply by ElectroMech
- First supply to a nuclear power plant by ElectroMech

The first Single Failure Proof (SFP) Crane was manufactured and despatched in March 2013. This was tested for full load and overload in our factory before despatch in the presence of a specialist team across NPCIL, QS Pune and NPCIL Mumbai. Several tests were conducted by simulating even the rare possibilities and our cranes satisfactorily passed all of them. The remaining 2 Single Failure Proof Cranes will be supplied during this financial year.

Single Failure Proof EOT Crane for NPCIL

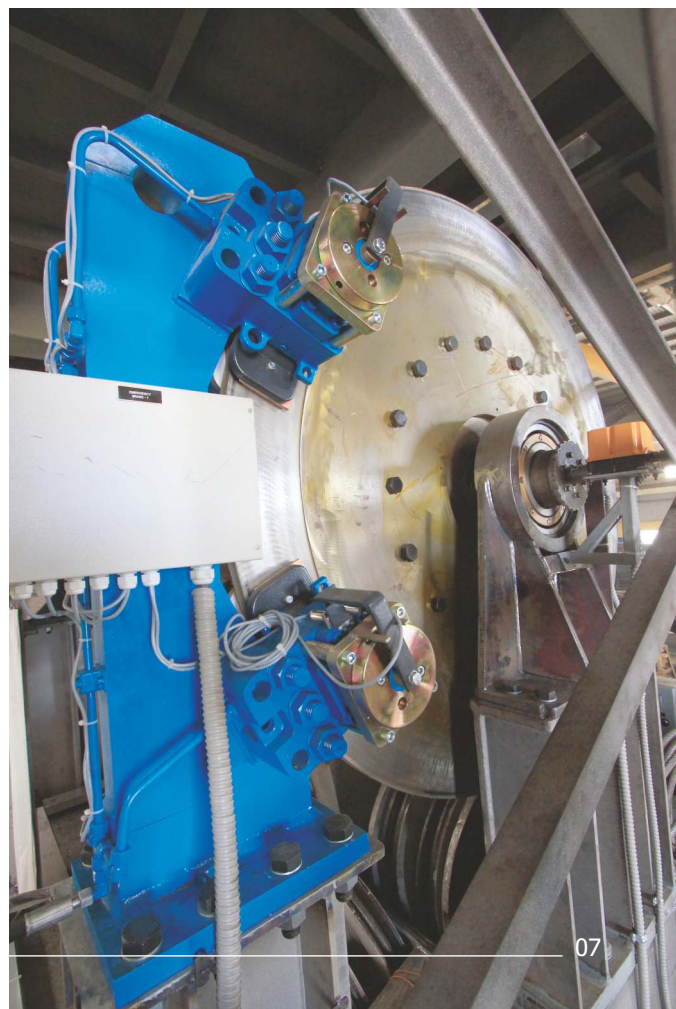
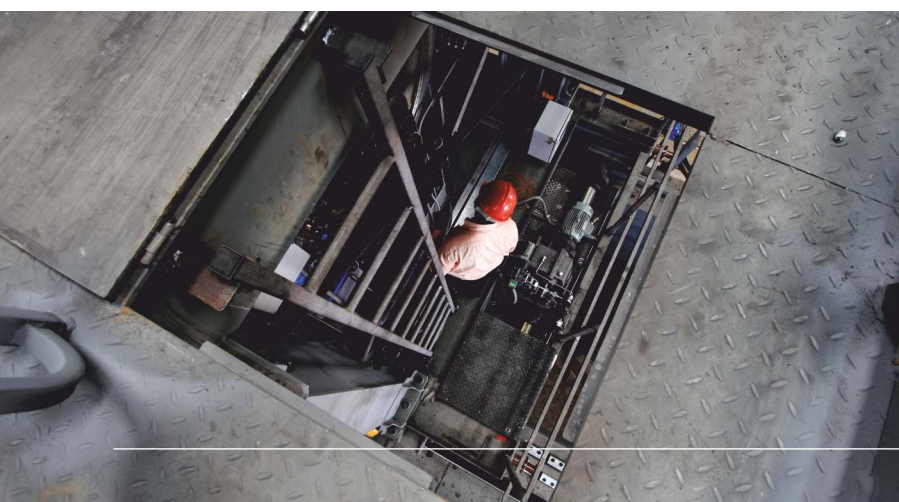
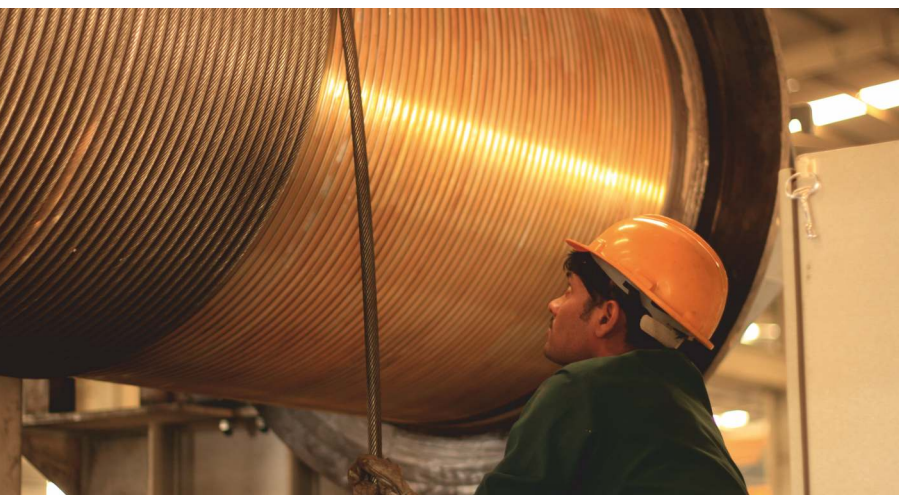

CMI FPE trusts our solutions capability

ElectroMech develops Pot handling crane with unique design by using 2 hoists on a single beam



CMI FPE Limited - formerly Flat Products Equipments India Ltd. was incorporated in 1986. The company, over

the last 22 years, has acquired a global leadership position in the design, manufacture, erection and commissioning of cold rolling mill complexes and auxiliary equipments for the cold rolling industry and the metal processing industry. The Belgian Group CMI (Cockerill Maintenance & Ingénierie) completed the acquisition of Flat Products Equipments India Limited in 2008 and has now been renamed CMI FPE Limited. The principal activities of the company comprise manufacturing and installation of cold rolling mills complexes, processing lines, chemical processes, thermal processes and automation equipments for ferrous and non-ferrous industries worldwide. As of today, CMI FPE Limited has a global footprint across Asia, Africa, Middle East, Europe, North America, South America and Russia.

The challenge

CMI FPE is currently working on a steel mill project for JSW Steel Ltd. at Tarapur, Thane. While working on this project, a big challenge was posed by the handling requirement at the galvanising plant. The company was looking for a Pot handling crane of suitable design to be fitted exactly above the zinc pot.

What is a Pot crane? Working and uses

These types of cranes are placed above the pots in galvanising plants. It is primarily a maintenance crane, used to maintain and replace the galvanising equipment such as rolls and slits when required. The space constraint is high, and precise hook positioning is required as the hook needs to be positioned exactly above the zinc pot.

ElectroMech solution

Having experienced our solutions capability previously, CMI FPE approached us to design a unique solution for their current challenge. The end client, JSW steel further attested this decision.

After carefully studying the process and the requirements, our design team developed a solution which was a perfect fit for their requirement. The design is very different from a conventional DG EOT crane.

The crane has 2 hoists of 7.5MT capacity each, mounted on cantilever beams hanging on the crab. The hoists were modified to suit this particular handling requirement. This design has been made for the specific application, considering the critical end approach requirements. The crane offers a span of 8m and lifting height of 18m. The overall system, in spite of the customised design, proved to be an economical solution for the client. This crane was under commissioning at the time of going to print.

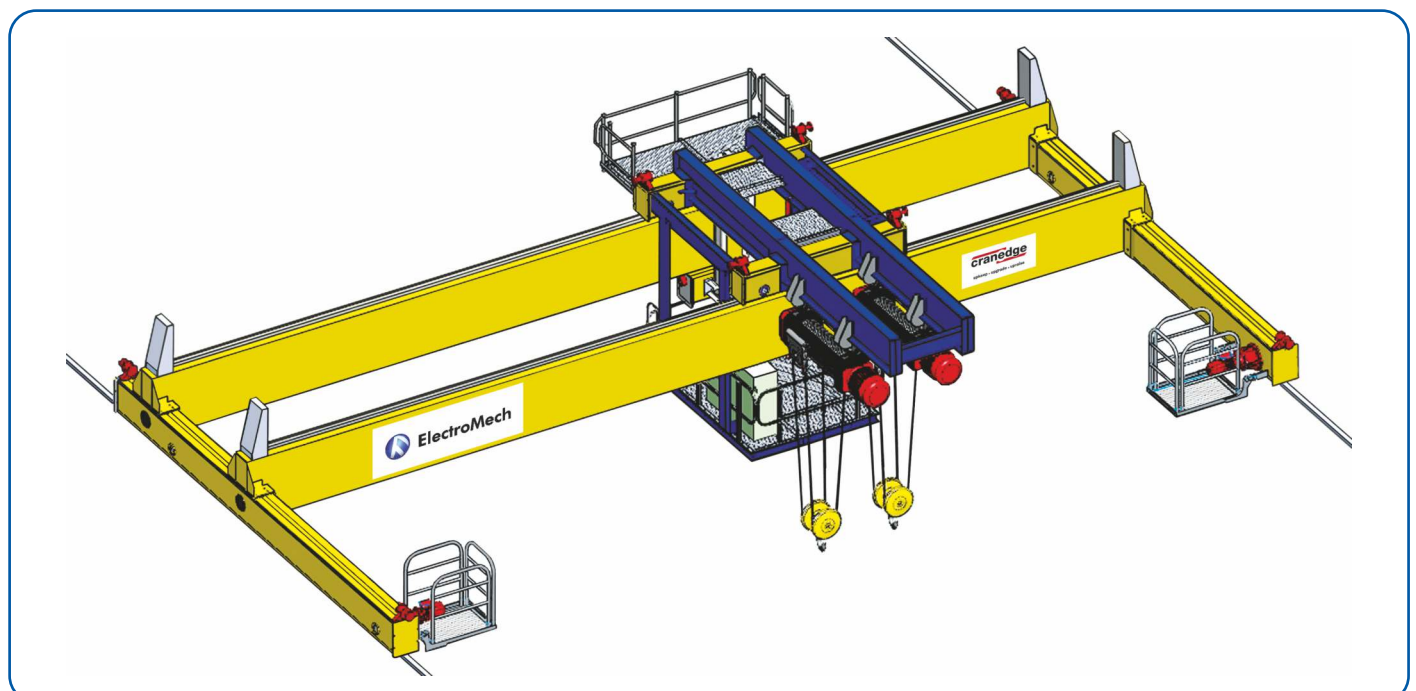

Prestigious order from Mazgaon Dock Limited

Intelligent design for overcoming space constraint to handle heavy loads

Mazgaon Dock Limited, Mumbai, an ISO 9001:2008 company is one of the leading shipbuilding and offshore fabrication yards in India. The yard was established in the 18th century, and over 200 plus eventful years, has earned a reputation for quality work and established a tradition of skilled and resourceful service to the shipping world in general and the Indian Navy, Coast Guards & ONGC in particular.

After 1960, Mazgaon Dock grew rapidly to become a premier warship building yard in India, producing sophisticated warships for the Navy and offshore structures for the ONGC. It has grown from a single unit, small ship repair company, into a multi-unit and multi-product company, with a significant rise in production, use of modern technology and sophistication of products. The company's current portfolio of designs spans a wide range of products for both domestic and overseas clients.

The challenge

Mazgaon Dock is in the process of expanding its facility to manufacture submarines for the Indian Navy. This is a very prestigious, challenging and critical project for the Indian Ministry of Defence. Handling requirements in this plant vary from a few tonnes to as high as 300 tonnes. Needless to say, safe handling of these critical components is of utmost importance. The frequency of utilisation and the operating speeds are very high. Further complicating these challenges is the fact that space availability is a great constraint in this plant.



Keeping this in mind, extensive engineering has been done to optimise the crane dimensions, to ensure maximum and effective space utilisation.

ElectroMech solution

After a thorough assessment of various crane manufacturers in India, Mazgaon Dock Limited selected ElectroMech to design, manufacture and commission the cranes for this new submarine manufacturing unit.

ElectroMech has designed 3-tier cranes to suit the client requirement. This type of design will ensure compact construction of the cranes to fit into the limited space available. We will be supplying 7 heavy-duty cranes. The client being a Defence organisation, the manufactured cranes will be undergoing close monitoring and quality checks from the officials of the Defence Ministry.

The order will be executed during the year 2014 and we are confident of meeting the expectations of the client.

Details of the order

- 150/30MT Semi-Goliath Cranes, Span 16m, HOL 22m-2 nos.
- 60/20MT Semi-Goliath Cranes, Span 23m, HOL 22m-1 no.
- 30/10MT DG EOT Cranes, Span 41.5m, HOL 32m-2 nos.
- 30/10MT DG EOT Cranes, Span 41.5m, HOL 27m-2 nos.



Thermax Ltd., headquartered in Pune, has been providing engineering solutions for decades to the energy and environment sectors. One of its biggest divisions supplies boilers to the power sector. The company recently entered into a joint venture with Babcock & Wilcox (USA), a global leader in the power generation industry, to manufacture super critical boilers for the power sector. The Thermax Babcock & Wilcox (TBW) plant is spread over 100 acres of land at Shirwal near Pune. The manufacturing facilities are split into 3 units; a 25,000 sq.m Section shop, a 16,000 sq.m Panel shop and a 18,000 sq.m Header shop.

ElectroMech has been supplying cranes to all of Thermax factories as well as their projects. The Thermax factory in Chinchwad, Pune has several cranes from ElectroMech and these are used for various applications like loading, unloading, handling, assembly work, etc. Satisfied with their past experience of using ElectroMech cranes, TBW approached ElectroMech at the planning stage itself to discuss the crane requirements for this new plant.

building structure and roof itself, the entire load of the crane as well as the job being handled is borne by the factory columns. Involving us at the factory planning stage is beneficial to a client as the structural engineer can optimise the factory building based on the wheel loads and crane dimensions provided by us. This also allows us to provide inputs on the workflow, so as to optimise the choice of cranes to keep costs low while achieving maximum resource utilisation.

Saving on project costs

The work of the TBW factory building started almost two years ago and following a consultative approach, ElectroMech designed a solution that was economical, had advanced features, matched speed, technical specifications and other parameters of the crane such as the geometries, wheel loads, etc.

An apt example of the benefit of involving us during the planning stage is seen in the plant's section shop. The highest capacity crane is 50MT, which would logically require the entire factory building to be designed for the loads exerted by this crane.



How project costs can be saved

A te

At the new TBW plant, 34 ElectroMech cranes with capacities ranging from 10MT to 50MT integrate the entire handling operations on three shop-floors. This covers handling right from raw material storage to the final despatch, including several fabrication and assembly stations.

The interesting part of this entire project was the involvement of ElectroMech right from the project conception and designing stage of the plant building. Consideration of overhead cranes in the plant is crucial in determining the overall specifications of the building. This is because overhead cranes run on gantry girders that are supported by the building structure. In addition to the

However, during detailed analysis of the client's work flow, it was apparent that the 50MT job would never traverse the entire length of the shop floor. This allowed the structure to be optimised so that only the necessary portion has been built to take the load from the 50 MT crane. Safety limit switches ensure that the 50 MT crane does not travel with its full load to other parts of the shop. This solution gave TBW substantial saving in their structural cost for this shop.

Reduced maintenance

ElectroMech advised TBW to opt for a power supply system, especially for the outdoor duty gantry cranes, that is more



reliable and has zero maintenance compared to what is used traditionally. Typically, for a gantry crane, one uses cable reeling drums. The cable reeling drum mechanism itself can prove to be problematic in some cases as it increases maintenance. Again, because we were involved with the customer from the beginning, we were able to factor in, at the time of construction itself, a way to use regular shrouded bus bar for supplying power to the outdoor gantry cranes. By this, we have eliminated a lot of hassles which might have arisen in the future had we resorted to the cable reeling drum concept. This approach has also led to further reductions in the project cost.

Power saving

Thermax has always used conventional cranes of the older generation of technology, based on the older Russian designs in their older plants. Cranes from ElectroMech used at the super critical boiler plant are more compact, efficient and lighter in weight. These cranes are reliable with practically no breakdowns and minimal requirement in regular maintenance. These cranes are also inverter-driven. Hence, there is better control on various

lean manufacturing philosophy dictates its reduction. By taking cognisance of what needs to be done on a shop-floor, arranging processes accordingly and by optimising speeds and geometries of cranes, material handling time can be drastically reduced. This needs to be planned in the early stages of the project to derive maximum advantage.



by involving ElectroMech at plant designing stage testimony at Thermax Babcock & Wilcox Ltd., Pune

parameters like smoothness of operation, precise control on speeds. Energy efficiency is further enhanced as cranes take only as much power as is required. If one were to combine the total power consumption of all the cranes used throughout the TBW factory, it would be observed that there is a reduction of at least 15-20 percent over conventional cranes.

Faster handling. Higher profits. Higher safety

ElectroMech has also supplied TBW with unique solutions like wall travelling cranes. On a shop-floor, with respect to the principles of lean manufacturing, waiting time is one of the prime sources of waste. Wall travelling cranes allow workers to service workstations individually without using cranes on the top. Waiting time for the crane is thus eliminated and productivity of the individual workstation is enhanced.

This is a much better solution than a semi-gantry crane, in which one end carriage runs on the gantry girder, while on the other side a leg runs on the floor. Having an end carriage running on the factory floor, creates a safety hazard due to the possibilities of collisions with men, machines and material. Rail tracks or supports would also be needed on the ground, increasing the civil cost. Wall travelling cranes have no legs and travel in the air independently on their own supporting structure integrated with the factory building, thus enabling efficient and safe layout of the workstation. Integrating wall travelling cranes into the layout was only possible because ElectroMech was involved in the project from the factory planning stage.

Customer satisfaction

Though material handling forms a critical part of any workshop,



Divisional Manager-Manufacturing, Thermax Babcock & Wilcox Energy Solutions Pvt. Ltd., Mr. Rajeev Sondur seconds the fact that including ElectroMech from the start provided numerous benefits. He said, "The company was able to fine tune our plant layout to ensure maximum space utilisation and save on our asset costs."

Adding further value is the ElectroMech factory, which uses almost every type of crane that we manufacture, acts as a showcase. This allows customers to experience a new solution that we may recommend to them, building their faith in the usefulness of the product.

We are indeed very thankful to the TBW team for reposing their trust in our solutions approach and capability and for involving us at the project planning and building designing stage.

Challenges

Thermax Babcock & Wilcox (TBW) wanted a material handling system that was technically proven, matched their applications and was cost-efficient.

Solution and Results

Wall travelling cranes were suggested by ElectroMech to TBW for carrying out their operations effectively; various zone protection systems were introduced which helped them save their structural cost. Inverter drives were used to save on power consumption.

Forging relationship

ElectroMech receives a prestigious order for 26 cranes from RKFL, Jamshedpur



Ramkrishna Forgings Ltd., Jamshedpur (RKFL) has planned an ambitious expansion project in the form of a new forging shop. The project will prove to be the biggest-ever investment at the major steel hub of India. It is noteworthy that RKFL has a remarkable tendency of going in for new trends in technology, adopting new solutions and giving a modern touch to its forging activities. RKFL selected ElectroMech and ABUS for this project based on their excellent experience with us in the past which prompted them to reaffirm their trust in ElectroMech.

This major order comprises 26 cranes that range in capacity from 2MT to 100MT. These cranes will be used for handling raw material and forging material such as large dies weighing 100MT each. ElectroMech will mainly harness the dependable ABUS range of products for the task. The specialty of the order placed on ElectroMech lies in the width of the range of ABUS cranes to be provided. The prestigious order will be completed successfully by the end of December 2013.

Thermax Babcock & Wilcox reposes its trust in ElectroMech

Awards another contract for 11 Double Girder Goliath Cranes for their Shirwal plant



Satisfied with the performance and service of the 32 cranes installed at their Shirwal, Pune plant, Thermax Babcock & Wilcox Energy Solutions Pvt. Ltd. awarded another contract for design, manufacturing, installation and commissioning of 11 Double Girder Goliath Cranes. These cranes will be mainly employed for outdoor material handling in their state-of-the-art super critical boiler manufacturing facility spread over more than 100 acres of land at Shirwal near Pune. The specifications of the cranes are as below,

Capacity	Span	HOL	Quantity
5MT	42.0m	10m	2
10MT	42.5m	10m	7
20MT	43.0m	10m	2

The order will be executed by December 2013. We thank the entire team of Thermax Babcock & Wilcox Energy Solutions Pvt. Ltd. for their continued support and selecting us as their reliable partner for material handling requirements.



A 'plate' full of challenges

One crane with 2 hoists avoids swing and allows higher span of Long Travel

JSW Steel Ltd. is a well-known name in steel manufacturing in India. For their Tarapur plant, they were looking for a suitable system to handle steel plates and long steel beams. These steel plates and beams, on coming out from a rolling mill are stacked adjacent to the mill. The client was looking for a suitable handling system which can efficiently handle and shift these plates to a nearby location.

JSW engineers approached ElectroMech to develop a suitable system for their unusual requirement. When our team studied the requirement, we discovered several challenges in the requirement. First of all, the long plates and beams necessitated hooking at two points to avoid swinging. The heavy loads up to 20MT demanded use of double girder cranes. The simplest solution would have been to provide 2 Double Girder EOT cranes which operate in tandem.

But the space constraint in the plant ruled out the possibility of using 2 DG EOT cranes as this would reduce the long traverse span which would not have met the client's requirement.

As always, out-of-the-box thinking by ElectroMech design engineers provided a unique solution for this project challenge. We designed one 20 MT DG EOT crane with 2 hoists of 10 MT

capacity each mounted on it. The hoists are placed 1 meter apart. This allows hooking at 2 different points and the possibility of jerks is completely eliminated. Specially modified ABUS hoists which work in tandem were used for this application. The use of only one DG EOT crane allows a higher span for long traverse, making optimum use of available shop-floor area, thus meeting the client's requirement. Also during routine operations, only one crane operator is required instead of two needed by the conventional system. Of course, using one crane of this type instead of two conventional DGEOT cranes has also reduced the equipment cost to the client.

The JSW team was extremely satisfied with our ingenious solution and the delight further enhanced when we commissioned the system within just 6 weeks from the confirmation of the order.



Customised solution for JSW Steel Ltd.



Zoomlion Tower Cranes for one of India's largest Cooling Towers

Global construction equipment giant Zoomlion and ElectroMech's Joint Venture partner in India for tower cranes has the distinction of having the second largest installed base of tower cranes in India. Over 550 Zoomlion tower cranes are in operation at various construction sites across the country. The Joint Venture company, Zoomlion ElectroMech India Pvt. Ltd. (ZEIPL) has been building on this formidable base and recently won an order for 2 TCT7527-20 flat top tower cranes to be supplied to Nagarjuna Construction company (NCC), where they will be used to build one of India's largest cooling towers. The first of these two tower cranes was recently delivered and commissioned.

Hyderabad-based NCC has a diversified presence across the burgeoning and growing core sector covering various segments

of infrastructure including the construction of buildings and housing, power, mining and railways, among others. The company is leveraging its rich expertise of the past years to address the job of projects execution at present with the sole objective of building India's future. NCC has an unmatched track record of strictly adhering to the project execution schedule without compromising on quality.

 **ZOOMLION** |

 **ElectroMech**

Being an important player in the field of power plant engineering and construction, the company has a portfolio of many BOT power projects. Currently, it is in charge of constructing two Natural Draught Cooling Towers (NDCT) for the 1320MW coal-based thermal power project on Muthukur Mandal, Nellore district of Andhra Pradesh.

The cooling towers will be 170m in height, with a base diameter of 145m and top diameter of 78m. To carry out the execution of

this challenging project, NCC has chosen TCT7527-20 Zoomlion Flat Top Tower Cranes which is the highest capacity flat top tower crane in Zoomlion's product portfolio. The crane has a maximum lifting capacity of 20t and tip load of 2.7MT at the 75m jib end, or 3.2MT at the 70m jib end. The crane is installed in the centre of the cooling tower.

These innovative TCT7527-20 Flat Top Tower Cranes are specially designed for cooling tower applications. The biggest advantage they offer is that once the cooling tower construction has been completed, the crane can self dismantle one section at a time. This is very important, considering the fact that a 75m jib needs to be dismantled, whereas the top opening of the cooling tower in which the crane will be standing is 78m in diameter.

The two cranes are supplied with 185.25m height under hook, and have several features, which include VFD motion in all

drives, provision of soft anchoring (sling support), enhanced drum capacity, localised 415V, 50Hz power connection, anemometer, jib & counter jib dismantling device and double trolley automatic reeving change system. Further, taking into account the typically hostile conditions at thermal power plant sites the cranes were specially finished with a unique 'heavy anti-corrosion coating scheme' which has been specially developed by Zoomlion.

To support NCC in this project, ZEIPL has provided on-site training along with a consumables spare stock to guarantee crane performance and develop customer speciality.

The Indian infrastructure construction market shows great interest in heavy capacity tower cranes, Zoomlion-ElectroMech has made it crystal clear that it offers an excellent solution to the emerging Indian infrastructure industry.

Zoomlion TCT7527-20 Flat top Tower Cranes delivered to help build one of India's largest Cooling Towers

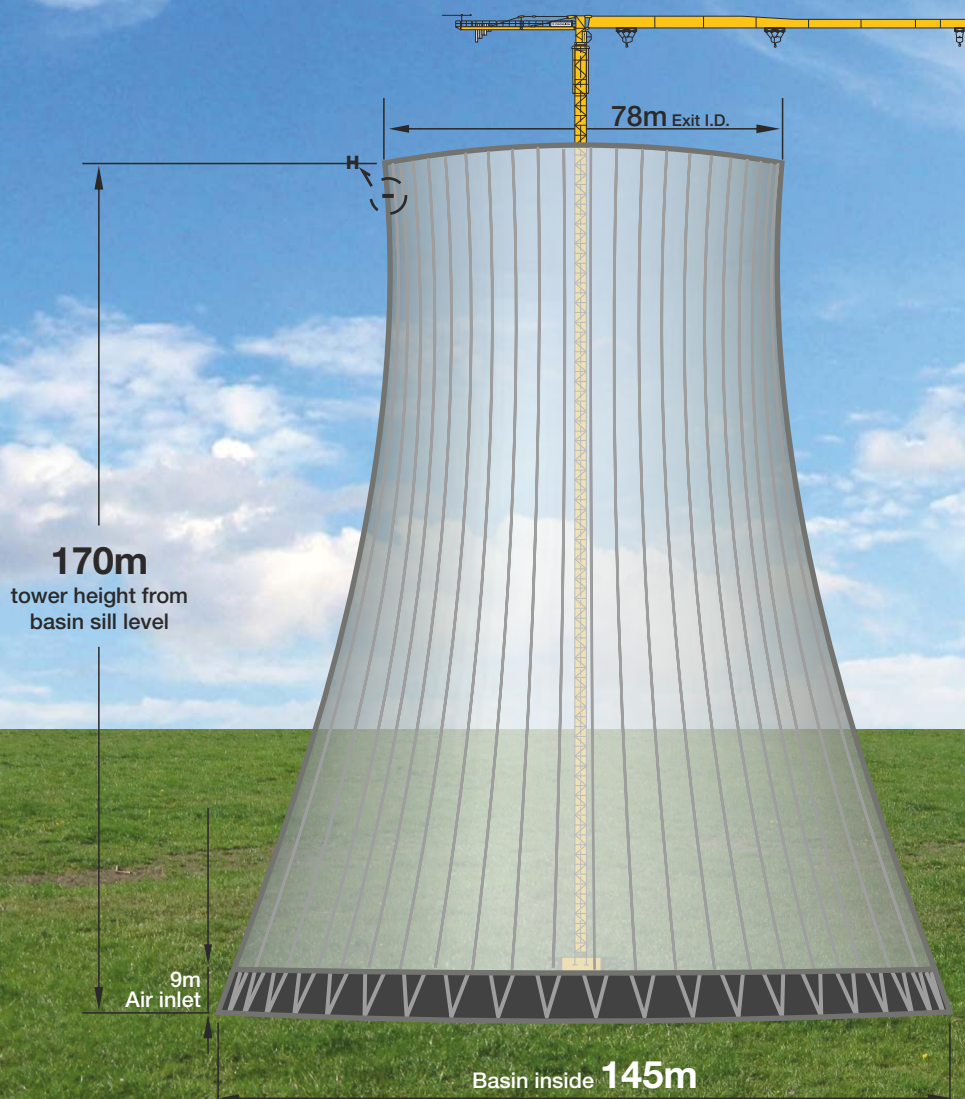

A new lease of life to a worn out crane of HCC

The Hindustan Construction Company (HCC) specialises in engineering and construction of complex infrastructure projects and has executed a large number of India's landmark infrastructure projects. HCC has been awarded some major contracts by Delhi Metro Rail Corporation (DMRC) and for the execution of these projects, they require various material handling equipments.

One such 25MT double girder gantry crane at their Mundka site, supplied by a European manufacturer was lying unused for several years. When the need for such a crane arose on a new project site, the HCC team intended to assess the possibility of refurbishing and using this crane. Knowing that the Cranedge team of experts is well versed with cranes of all makes, HCC approached us to carry out the task. The Cranedge team first conducted a Crane Health Assessment to evaluate the possibility of reusing the crane by refurbishing and bringing it back to the original condition without compromising on safety and performance.

The Crane Health Assessment report prepared after thorough evaluation and analysis revealed that most of the components were completely rusted and moving components were jammed because of rust and grime. This included key components and various sub-assemblies such as the crab assembly, wheel assemblies for long travel & cross travel, rope drum, lower block, etc. A few control panel covers and the wiring inside the panel



was completely missing. The gearbox was in a relatively good condition, but needed cleaning and oil change, whereas the operator cabin was in a completely derelict condition.

For refurbishing this crane properly, we decided to bring the key parts such as the crab assembly, long travel wheel blocks with motors and the operator cabin to our Pimpri, Pune factory. The entire work was completed to great satisfaction of the client and trials and tests of major components were conducted in our factory for rigorous performance.



Delhi Metro Rail Corporation
(DMRC)

Another factor that demanded attention was that the crane had been supplied by the OEM with motors compatible with 60Hz power supply. However, these kind of motors typically overheat when subjected to the standard Indian 50Hz power supply. On Cranedge's recommendation, Variable Frequency Drives were added for all motors to avoid overheating.

The HCC team was extremely happy with the solution and services of Cranedge. HCC was able to save a considerable



upkeep • upgrade • upraise

Cranedge introduces unmatched, localised services for Zoomlion Tower Cranes

With over 550 installations in India, Zoomlion is a familiar name for tower cranes in the country. Their world-class quality, wide ranging solutions and competitive pricing have established Zoomlion as the world's largest manufacturer of tower cranes. The Zoomlion ElectroMech Joint Venture aims to cement the Zoomlion brand in India further through best-in-class leading products and services. Service for new as well as existing

customers will be provided by ElectroMech's service subsidiary, Cranedge.

To demonstrate our commitment to serve this market efficiently, Cranedge conducted its first **Service Campaign** along with the new Joint Venture company, Zoomlion ElectroMech India Pvt. Ltd. (ZEIPL)

On May 06, 2013 the Service Cruise was flagged-off from Pune and over the next two weeks, we met several customers in Pune, Mumbai, Bangalore, Cochin, Chennai, Hyderabad and Delhi NCR.

This service cruise was undertaken to meet existing Zoomlion customers and introduce ourselves as the exclusive partner for providing a complete range of services for Zoomlion tower cranes. Project managers, equipment maintenance managers and tower crane operators were given a refresher programme on the superior features of Zoomlion tower cranes. We conducted 'on-the-crane-training' covering operation, maintenance and



amount of money thanks to the methodical approach and proper engineering solutions from Cranedge to grant a new lease of life to the completely worn out crane. The modification of the existing trolley has resulted in a huge direct saving for HCC both in terms of costs and time. Had HCC procured a new trolley to match the application and fitment on the crane, it would have cost them at least 4 to 5 times more! At the same time, the modification undertaken by Cranedge has saved the customer at least 12 weeks of valuable time which, when calculated over the project time line is a significant and crucial saving.

Gearbox

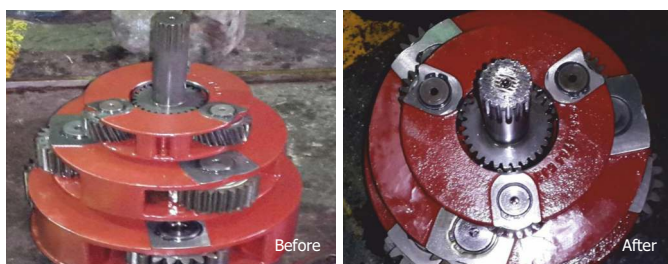

Crab

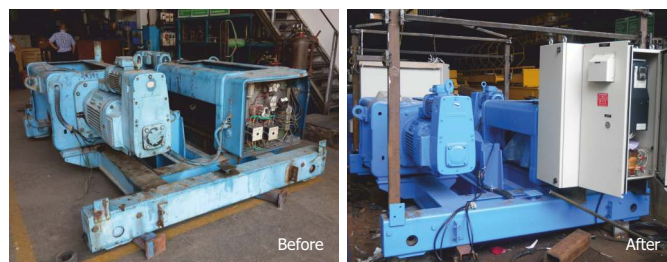

Wheel block



safety protocol for the operators followed by an interactive session about their experiences while using the existing tower cranes and collected valuable feedback.

Our clients were reassured of our presence and our long-term commitment to serve them with great efficiency through a team of trained and competent technicians. Our nationwide network is a further assurance to render services wherever they are. Our customers can always expect a wide range of services from us, including ready supply of genuine spares, trouble shooting, any type of repairs or breakdown services, Annual Maintenance Contracts, One Time Health Checks, electrical upgrades, operator training courses or any other technical support and consultancy on the selection, operation and maintenance of tower cranes.

The response to our service campaign was overwhelming. Our customers are delighted at the prospect of now being able to

associate with the OEM service organisation and not having to depend on local sources.

We would like to express our sincere thanks and gratitude to our customers for their strong support, co-operation and active participation in making this Service Cruise a very promising start to our endeavours.





A high-lift, high-speed crane in operation at an HCC Hydroelectric Power Project in Punatsangchu, Bhutan



Mr. AVR Murty, CEO, receiving the award on behalf of ElectroMech

Award-winning solution for tunnelling operations

'Manufacturing today' award for 'Excellence in Innovation' in the SME category

ElectroMech is proud to have been awarded for our innovative solution provided for the execution of the Mumbai water supply project. ElectroMech, India's largest industrial crane manufacturer and customised material handling solutions provider was awarded the **'Excellence in Innovation'** award in the SME category for its specialised Tunnel Mucking System at the 'Manufacturing Today awards 2012', conducted by 'Manufacturing Today', an ITP Publication group magazine.

Commenting on the occasion, Mr. Tushar Mehendale, Managing Director, ElectroMech said, "We are very pleased to receive the award for our path-breaking innovation. This award testifies that we continue to align our innovation approach to meet our customer expectations. This unique Tunnel Mucking System is a boon for projects which require rapid removal of overburden from tunnelling or shaft excavation and has its own benefits as a special purpose crane. We will remain committed to our customers and continue to offer the best products."

ElectroMech's clients for its high-speed, high-lift Tunnel Mucking Systems include several leading infrastructure majors such as Gammon, HCC, Unity, Patel Engineering, SOMA and IVRCL on sites in India and across the globe.

ElectroMech's unique Tunnel Mucking System has proved to be an innovation in various critical projects for rapid removal of overburden from tunnelling or shaft excavation. The recent installations for the Mumbai water supply project involved ElectroMech's tunnel mucking crane under the government's Jawaharlal Nehru National Urban Renewal Mission (JNNURM). The INR 2235 crore project was divided into two parts. The construction work of this prestigious project was awarded to two construction majors namely, Soma Construction Company for Phase I (Gundovali to Thane) and to a Joint Venture of Unity Infraprojects Ltd. and IVRCL Ltd. for Phase II (Thane to Bhandup). Interestingly, ElectroMech supplied tunnel mucking cranes to both the companies, thus playing a crucial role in BMC's ambitious 24x7 water supply project.



IVRCL & ElectroMech teams



| Solutions | Service | Satisfaction |

Our customers reaffirm our positioning.

A recent customer satisfaction survey by Nielsen reveals the fact*.

Customer satisfaction is a top priority for ElectroMech. Every action, effort and the organisational energy are directed towards keeping our customers satisfied. It is of course important to keep track of changing customer expectations and where we stand while fulfilling them. To achieve this, we interact with our customers on several platforms such as conferences, exhibitions and customer visits by our sales team. This customer-centric approach has helped us win the trust of thousands of crane users in India and abroad. Satisfied with the ElectroMech experience, our existing customers invariably approach us for their new requirement of cranes. At the same time, new customers, some of them users of other brands of cranes, who are looking for better solutions, service and experience approach us as well.

To further augment our efforts, a more systematic approach in this direction was recently initiated by conducting a pan-India survey among our customers through Nielsen, a premier global market research organisation. The survey findings are very encouraging and have provided insight and clues for further improvements to excel in our field of operations.

According to this survey, the attributes about ElectroMech most appreciated by our customers were:

- The overall performance of our products
- Domain knowledge and skill set of team members while understanding customer requirements
- Our ability to provide customised solutions which are most relevant for a particular application
- Professional and ethical practices followed by the company
- The technical competency of our team of engineers
- Our customer-oriented approach

Over the years, we have evolved as a leading and capable 'Solutions provider'. For this, we always ensure strong technical and design support to our customers. To provide the most pertinent solutions, our R&D team is constantly exploring ways to improve our products and deliver a better customer experience. Apart from this, we lay a great emphasis on adopting most modern manufacturing practices which ensure high quality and reliability of our cranes. This, in turn, translates into a greater benefit for our customers. According to them, the following are the important benefits with our crane systems.

- Safety features of equipment
- Smoothness and low noise levels of equipment
- Necessary safety and statutory regulations followed by our installation team

Apart from the above, customers have appreciated our systems during and after the tendering process. According to them,

- Accuracy, completeness and timely submission of technical documentation are highly satisfactory
- Interaction, courtesy and politeness of the sales team are appreciable
- Majority of our customers also admired our ability to provide 24x7 service support
- ElectroMech deploys a well-trained and skilled team of engineers and technicians on the field to provide numerous trusted services



nielsen
.....

Survey highlights

- **ElectroMech is mainly known for providing customised solutions, technical competency, excellent product performance and customer-centric approach.**
- **9 out of 10 customers will definitely recommend our cranes and services to other businesses.**
- **ElectroMech has the highest recall amongst all the crane brands in India.**

A very encouraging comment received in response to the question, "How likely are you to recommend ElectroMech and Cranedge Service to a business associate?" For calculating the Net Promoter score on a scale of 0 to 10 - ElectroMech was rated 9.

Also, when the customer was asked for a 'top-of-the-mind' recall we were happy to know in terms of awareness ElectroMech is the leading brand name for EOT cranes in India.

At ElectroMech, we have taken cognisance of all the feedback from our clients and are implementing certain changes to increase customer satisfaction. For example, Radio Remote Controls have been made standard across our range of cranes based on customer feedback during this survey.

We thank all our customers for participating in this survey and provide us with their valuable time and feedback.

*Source: Nielsen Survey February 2013 (sponsored by ElectroMech)



Zoomlion - ElectroMech Tower Cranes make a debut at bC India, 2013



During the year 2012, ElectroMech joined hands with the Chinese construction machinery giant to manufacture and sell their range of tower cranes in India through a Joint Venture.

With the formation of Zoomlion ElectroMech India Private Limited (ZEIPL), the construction industry in India can look forward to having Zoomlion's entire range of tower cranes as well as several 'made for India' models available to them. They can also count on the reliable service support of our service subsidiary, Cranedge throughout India.

Our stall spread over nearly 4000sq.ft. in an open area was designed in an innovative way to make it more visitor-friendly. The stall was visited by a large number of people from construction and infrastructure industries. The entry of

ElectroMech into the tower crane market was enthusiastically appreciated by several of them. According to them, after-sales-service is a major lacuna with most of the tower crane brands available in India and ElectroMech can certainly score over them considering our experience in industrial cranes services through an extensive nationwide network.

Also on display were ElectroMech's Gantry cranes which are being extensively used for construction of flyovers, elevated freeways, roads and bridges. Using the concept of gantry cranes, we have also developed specialised tunnel mucking systems for removal of muck during shaft or tunnelling operations. Several such systems are already operational on various construction sites and infrastructure projects in India and abroad.

ElectroMech Editorial Team: Suhail Bajaj, Ruthu Devadiga, Ashwini Deshpande



ElectroMech

| Solutions | Service | Satisfaction |

ElectroMech Material Handling Systems (India) Pvt. Ltd.

Corporate Office & Plant
Gat No. 316, At post Kasar Amboli, Tal. Mulshi,
Dist. Pune 412 111 INDIA
Telefax : +91-20-6654 2222 E-mail : cranes@emech.in

Branch Offices

Ahmedabad : 099043 53700
Bengaluru : 099008 15071
Chennai : 099406 57525, 093812 23925
Delhi : 097177 79432
Kolkata : 098740 64646
Mumbai : 090110 99418
Dubai ElectroMech FZE : ++971-4-8857466

www.emech.in